

Actuator

22-
211.011



<https://eao.com/p/22-211.011>

Your product:



22-211.011 Actuator

FRONT

Front dimension:	36 mm x 24 mm
Front form:	rectangular
Front bezel colour:	Black
Front bezel material:	Plastic

MOUNTING

Design:	flush
Mounting cut-out:	22 mm x 30 mm
Mounting type:	Panel mounting

OPERATING-/INDICATION PART

Lens illumination:	optional illuminative
---------------------------	-----------------------

ELECTRICAL CHARACTERISTICS

Contacts:	1 NO
Switching voltage and switching current:	400 VAC, 10 A (ohmic) 400 VAC, 4 A (inductive, $\cos(\phi) = 0.7$) 250 VAC, 5 A (inductive, $\cos(\phi) = 0.7$) 125 VAC, 8 A (inductive, $\cos(\phi) = 0.7$) 110 VDC, 0.4 A (inductive, L:R = 30 ms) 60 VDC, 1.5 A (inductive, L:R = 30 ms) 24 VDC, 6 A (inductive, L:R = 30 ms)
Rated insulation voltage U_i:	400 VAC/440 VDC according to IEC 60947-5-1
Switching rating:	400 V @ 10 A
Electrical lifetime:	50 000 cycles of operation
Electric strength:	

2000 VAC, 50 Hz, 1 minute, as per IEC 60512-2-11 between all terminals and earth

Standards: The switches comply with the "Standards for low-voltage switching devices" EN IEC 60947-5-1

Thermal current I_{th}: 10 A

MECHANICAL CHARACTERISTIC

Terminal: Screw terminal

Contact material: Silver

Switching action: Momentary

Switching system: Snap-action switching element

Switching system: Self-cleaning, double-break snap action switching system (contact opening width 2 mm x 1.5 mm).
Max. 2 normally closed or 2 normally open contacts, or one of each

Mechanical lifetime: 1 Mio. cycles of operation

Operating force: 4.4 N ±1 N (1 switching element), 7.8 N ±1 N (2 switching element)

Operating Travel: 5.5 mm ± 0.5 mm

Travel: > 3 mm

Tightening torque: Fixing nut max. 0.2 Nm, Screw terminal 0.8 Nm

Weight: 0.044 kg

AMBIENT CONDITION

IP Protection: IP20 rear side, IP65 front side, according to IEC 60529

Operating temperature: – 25 °C ... + 55 °C

Storage temperature: – 40 °C ... + 95 °C

Shock resistance: 50 g for 11 ms, according to IEC 60512-4-3

Vibration resistance: 10 g at 10 Hz...2000 Hz, amplitude 0.75 mm (Sinusoidal), according to DIN EN 60512-4-4

CERTIFICATE

Approbations: CB (IEC 61058-1), CSA, EAC, ENEC (EN 61058-1), UL

Conformities: CE, UKCA, 2011 / 65 / EC (RoHS), 2014 / 35 / EU (LVD)

REACH: REACH compliant

RoHS: RoHS compliant

OTHER

Short Description:

Actuator, 22 mm x 30 mm, 36 mm x 24 mm, optional illuminative, rectangular, Black, Plastic, 1 NO, Momentary, Screw terminal

Housing colour:

Black

Housing material:

Plastic

Wiring diagrams:

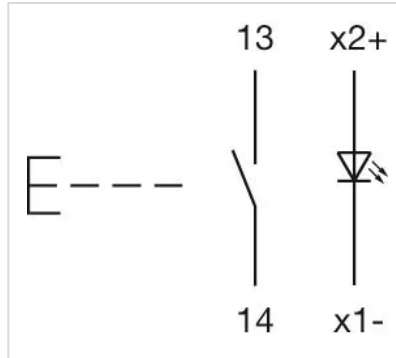

Mounting cut-outs:

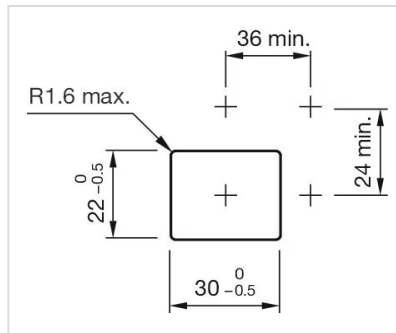

Dimension drawings:

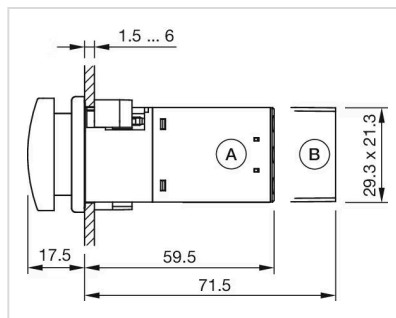

A = Screw terminal
B = Plug-in terminal 6.3 mm x 0.8 mm

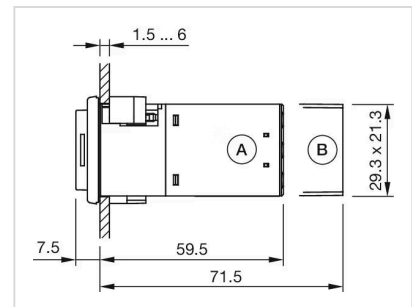

A = Screw terminal
B = Plug-in terminal 6.3 mm x 0.8 mm