

# Illumination element

45-320.1F42

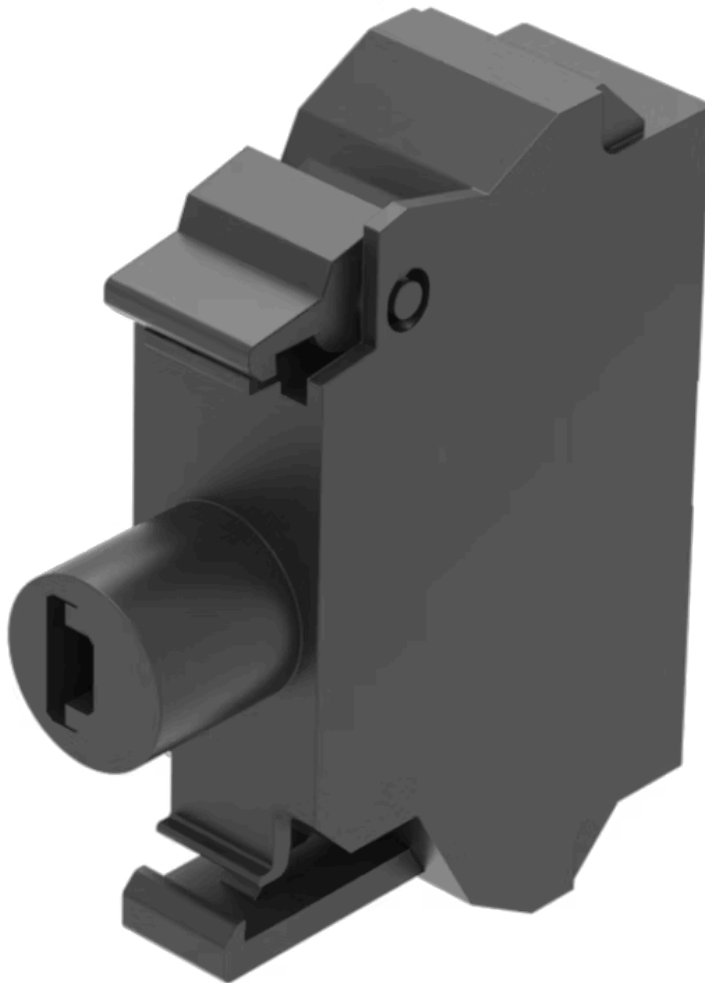

<https://eao.com/p/45-320.1F42>

Your product:

---



## 45-320.1F42 Illumination element

### MOUNTING

**Component mounting type:** Front mounting

### OPERATING-/INDICATION PART

**Illumination colour:** Amber

### ELECTRICAL CHARACTERISTICS

**Operating voltage:** 24 - 240 V AC/DC

**Surge voltage resistance:** 4 kV

**Lumi. Intensity:** 450 - 1120 mcd

### MECHANICAL CHARACTERISTIC

**Terminal:** Spring-type terminal

**Weight:** 0.01 kg

### CERTIFICATE

**REACH:** REACH compliant

**RoHS:** RoHS compliant

### OTHER

**Short Description:** Illumination element, Spring-type terminal, Amber, 24 - 240 V AC/DC, Front mounting

**Wiring diagrams:**

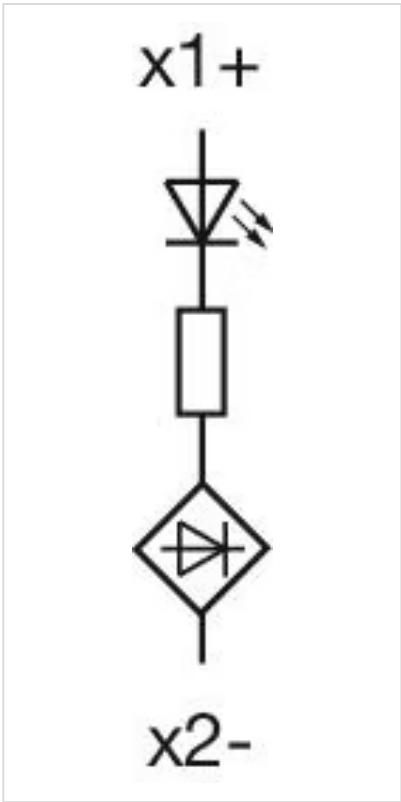

Dimension drawings:

