

# Legend frame

45-569.1112



<https://www.eao.com/component/45-569.1112/en/...>

Your product:

---



## 45-569.1112 Legend frame

### FRONT

**Colour:** Black

### MOUNTING

**Mounting type:** For sticking or snapping in place

### MECHANICAL CHARACTERISTICS

**Weight:** 0.003 kg

### OTHER

**Short Description:** Legend frame, 27 mm, Plastic, For sticking or snapping in place, Black

**Title Accessory:** Legend frame

**Dimension:** 27 mm

**Material:** Plastic

**Product attributes:** For legend 27 mm x 27 mm

**Dimension drawings:**

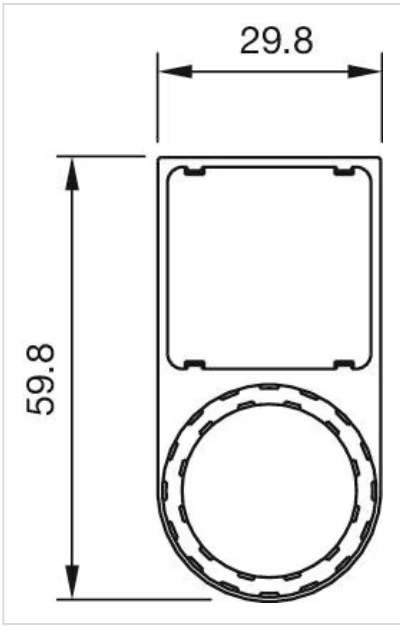

for Part No. 45-569.1112