

Lamp block

704.951.1



<https://www.eao.com/p/704.951.1>

Your product:



704.951.1 Lamp block

ELECTRICAL CHARACTERISTICS

Standards: The switches comply with the "Standards for low-voltage switching devices" DIN EN 60947-1/DIN EN 60947-5-1

MECHANICAL CHARACTERISTICS

Terminal: Plug-in terminal, 6.3 x 0.8 mm

Switching positions: 3 positions

Wire cross section: Plug-in terminal 1 x 6.3 mm x 0.8 mm or 2 x 2.8 mm x 0.8 mm
For switches with plug-in terminals it is necessary to provide insulation sleeves and to maintain a spacing of 65 mm between rows (mounting cut-outs).

Weight: 0.013 kg

AMBIENT CONDITION

IP Protection: IP00

Operating temperature: - 40 °C ... + 55 °C

Storage temperature: - 40 °C ... + 85 °C

Shock resistance: Max. 300 m/s², pulse width 11 ms (sinusoidal EN IEC 60068-2-27)

Vibration resistance: Max. 100 m / s² from 10 Hz ... 500 Hz, (sinusoidal EN IEC 60068-2-6)

Climate resistance: Relative humidity, max. 95%, non-condensing

CERTIFICATE

REACH: REACH compliant

RoHS: RoHS compliant

OTHER

Short Description:

Lamp block, Plastic, Plug-in terminal, 6.3 x 0.8 mm

Housing material:

Plastic

Hints:

When using the lamp block, the application guidelines must be observed.

Wiring diagrams:

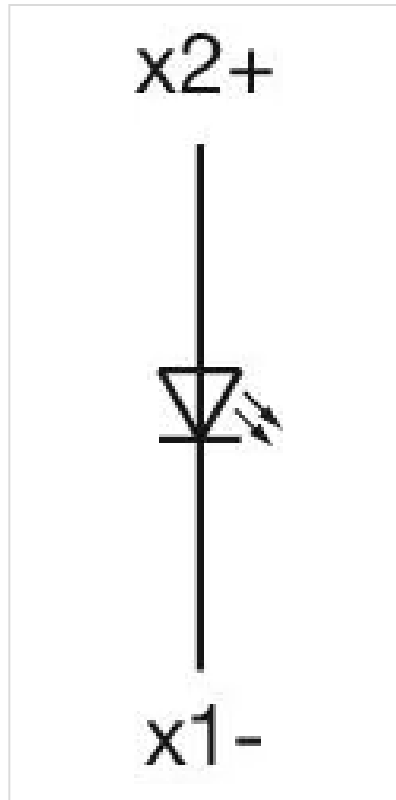

Dimension drawings:

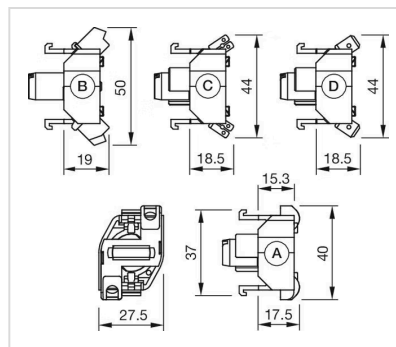

A = Screw terminal
B = Push-in terminal (PIT)
C = Plug-in terminal 6.3 mm x 0.8 mm
D = Double plug-in terminal 6.3 mm x 0.8 mm