

# PCB快插基板

31-940

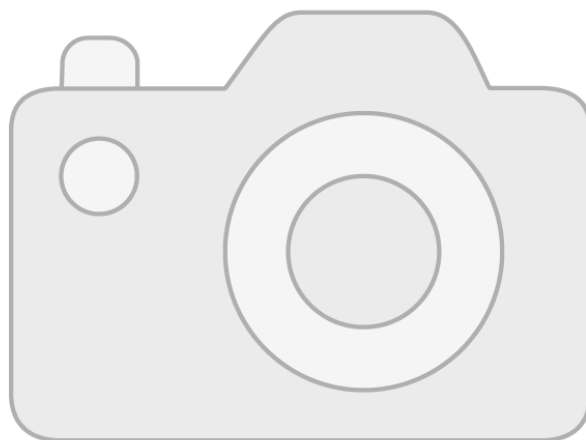
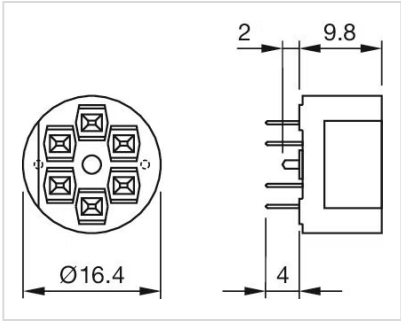

Image not available



<https://www.eao.com/component/31-940/zh/pcb>





对于 Part No. 31-940